



# OPERATING MANUAL Gfp 355TH/363TH

**Please read this manual carefully before operating!**



**Unpacking, assembly, and operating videos are available at  
[www.gfppartnersllc.com](http://www.gfppartnersllc.com)**

355TH beginning with S/N 1905355TH069  
363TH beginning with S/N 1903363TH043

## Table of Contents

Contents	Page
1. Introduction .....	3
2. Important Safety Instructions.....	3
3. Installation Safeguards .....	3
4. Regulatory Compliance Statement.....	4
5. General Safeguards.....	5
6. Operating Conditions.....	6
7. System Components.....	7
8. Control Panel.....	8
9. Packing List .....	9
10. Installation	
A. Uncrate the machine.....	10
B. Remove stand cross members.....	11
C. Assemble machine stand.....	12
D. Set Machine on stand.....	13
E. Bolt Machine to stand.....	14
11. Additional installation items.....	14
12. Loading upper shafts	
A. Remove upper supply and rewind shafts.....	15
B. Loading film and rewind shafts.....	16
13. Loading bottom supply shaft	
A. Media alignment disks.....	17
14. Threading film.....	18
15. Adjusting Brake/Clutch Tensions.....	19
16. Operation.....	20
17. Roller gap.....	20
18. Laminating	
A. Single sheets using a sled.....	21
B. Multiple sheets using a roll of Kraft Paper.....	21
C. Media from a roll.....	22
19. Mounting	
A. Pre-coating mounting boards.....	23
B. Mounting print to pre-coated mounting board.....	23
20. Troubleshooting .....	24
21. Specifications.....	25
22. Warranty.....	26

## 1. Introduction

Thank you for choosing a Gfp 300 Series laminator. It has been designed and manufactured to provide years of continuous service. Please read this manual thoroughly before operating. Please inspect the box and the laminator for shipping damage. Damage should be brought to the attention of the delivering carrier immediately

We reserve the right to make changes to this publication and to the products described in it without notice. The details given in this manual are based on the most recent information available to us. They may be subject to change in the future. We retain the right to make changes to the construction or the design of our products without accepting any responsibility for modifying earlier versions

**WARNING!** Any unauthorized changes or modifications to this unit without our prior written approval will void the user's warranty and will transfer health and safety obligations to the end user.



**CAUTION!** Please pay attention to all passages with these symbols. This information is vital to preventing user injury and/or damage to the unit. Failure to follow this information could void the user's warranties and transfer all safety obligations to the user.

## 2. Important Safety Instructions

In this operating manual you will find important safety messages regarding the product. Read these instructions carefully, failure to comply with the following safety procedures could result in serious injury.



**WARNING** Do not attempt to service or repair the laminator. Only authorized maintenance and service technicians should make repairs.

**WARNING** Do not connect the laminator to an electrical supply or attempt to operate the laminator until you have completely read these instructions. Maintain these instructions in a convenient location for future reference.

**WARNING** To guard against injury, the following safety precautions must be observed in the installation and use of the laminator

## 3. Installation Safeguards

- Shipping damage should be brought to the immediate attention of the delivering carrier
- Avoid locating the laminator near sources of heat or cold. Avoid locating the laminator in the direct path of forced, heated or cooled air
- The receptacle must be located near the equipment and easily accessible.
-  Connect the attachment plug provided with the laminator to a suitably grounded outlet only. This machine must have reliable earth wire to ensure the safety of the machine during operations
- Contact an electrician should the attachment plug provided with the laminator not match the receptacles at your location

-  Ensure that the voltages of the power supply you are using match the rated working voltages before operations. Do not use incorrect power supply
-  Do not use damaged wires or sockets. If abnormal conditions occur, switch off the power supply first.
-  Only a licensed electrician should install wiring and outlet for the laminator
- Do not defeat or remove electrical and mechanical safety equipment such as interlocks, shields and guards

## 4. Regulatory Compliance Statements



### cTUVus Certification

This test mark, also referred to as the "cTUVus mark", serves as proof of compliance with US national standards from UL adopted by OSHA and the Canadian national standards of CSA adopted by the Standards Council of Canada (SCC). US Authorities having Jurisdiction (AHJs) and Provincial Regulators across Canada recognize the cTUVus mark as proof of product compliance to published national standards and code requirements. The cTUVus mark is officially recognized as an equivalent and direct replacement of the UL and CSA marks.



### Federal Communications Commission (FCC) Compliance Statement



This equipment has been tested and found to comply with the limits for a Class B digital device, pursuant to part 15 of the FCC Rules. These limits are designed to provide reasonable protection against harmful interference in a residential installation. This equipment generates, uses and can radiate radio frequency energy and, if not installed and used in accordance with the instructions, may cause harmful interference to radio communications. However, there is no guarantee that interference will not occur in a particular installation. If this equipment does cause harmful interference to radio or television reception, which can be determined by turning the equipment off and on, the user is encouraged to try to correct the interference by one or more of the following measures:

- Reorient or relocate the receiving antenna.
- Increase the separation between the equipment and receiver.

- Connect the equipment into an outlet on a circuit different from that to which the receiver is connected.
- Consult the dealer or an experienced radio/TV technician for help.

Changes or modifications not expressly approved by the party responsible for compliance could void the user's authority to operate the equipment.

## 5. General Safeguards

- Keep hands, long hair, loose clothing, and articles such as neckties away from rollers to avoid entanglement and entrapment. The rollers have pinch points that can trap body parts or clothing and cause serious injury
- Do not use the machines for purposes other than lamination and mounting, otherwise damages to the machine or accidents may occur
- Keep out of reach of children
- Keep flammable and wet objects away from the machine.
- Do not use flammable sprays or materials when cleaning the machine
- Do not leave the machine unattended during operations.
- Do not mount metal materials or other hard objects.
- Do not put burrs, sharp blade or rigid materials in between the two rubber rollers.
- Do not attempt to laminate items that exceed total recommended material thickness of the unit.
- Do not place foreign object inside the machine.
- Do not cut adhesive films directly on the surface of the rollers to avoid damaging the rubber coating.
- Shut down the machine after laminating to avoid misusing this machine by others.
- Shut down the power before moving the machine
- Note the locations of foot wheels while moving or operating this machine to avoid injuries to your feet.
-  Disconnect from the power supply before repair or maintenance.
-  Disconnect from the power supply when the machine is not in use for a long time.
- When the machine lies idle for a long period of time, raise the top rubber roller to avoid the distortion of the rubber surface.
- Perform only the routine maintenance procedures referred to in these instructions
- Do not leave excess adhesive build up on the rollers overnight

## 6. Operating Conditions

- Place machine on level surface
- Environment requirements :  
Ambient temperature: 50° F - 104° F  
Humidity : 30%—80% ; ideal humidity : 55%
- Due to the static on film rolls, you should try to keep the environment clean.
- Provide enough space around machine to ensure the safe and effective operation. The minimum area covered is 8 ft. x 10 ft.
- Do not directly cut the films on the surfaces of the rubber rollers to avoid damages to the rollers.
- Do not put burrs, sharp knives or extra thick and hard materials in between the rollers. Do not leave objects like tools, rulers, knives, etc. on the working panels or the side cabinets to avoid their being rolled into the machine accidentally and damaging the rollers.
- For repairs and replacements, please contact your local distributor. Unauthorized repairs and dismantling will affect future maintenances of the machines.
- The machine can laminate continuously objects less than ½” thick.  
For objects over ½” but less than 1” thick, use the pedal switch.



***Warning: Do not keep the machines in direct sunshine or near it.  
Do not keep the machine in dusty place or places with strong vibrations.***

## 7. System Components

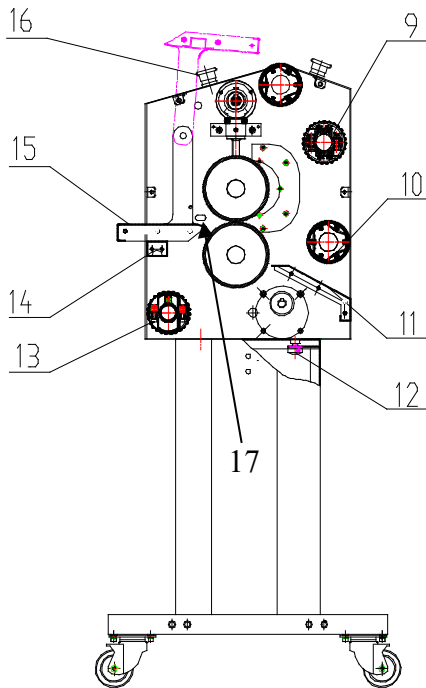
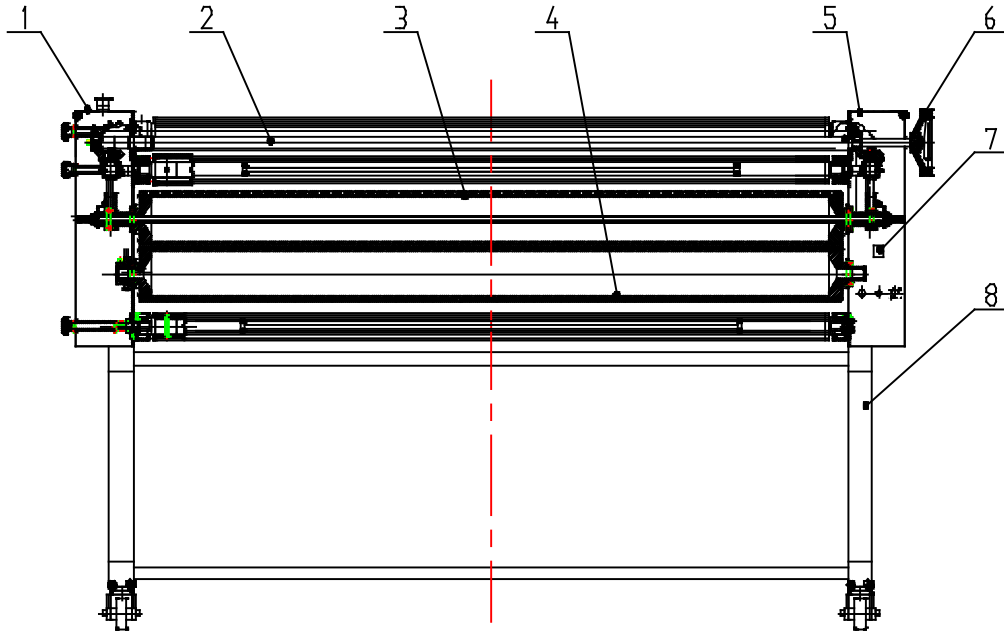

1. Left Cabinet
2. Pressure Adjustment linkage shaft
3. Top Rubber Roller
4. Bottom Rubber Roller
5. Right Cabinet
6. Roller gap adjustment Hand Wheel
7. Power Switch
8. Stand
  
9. Top supply shaft
10. Rear rewind shaft
11. Rear Exit panel
12. Anchor bolt.
13. Bottom supply shaft
14. Front cross member
15. Swing up feed tray
16. Emergency Stop Switch
17. Photo eye opening

## 8. Control Panel

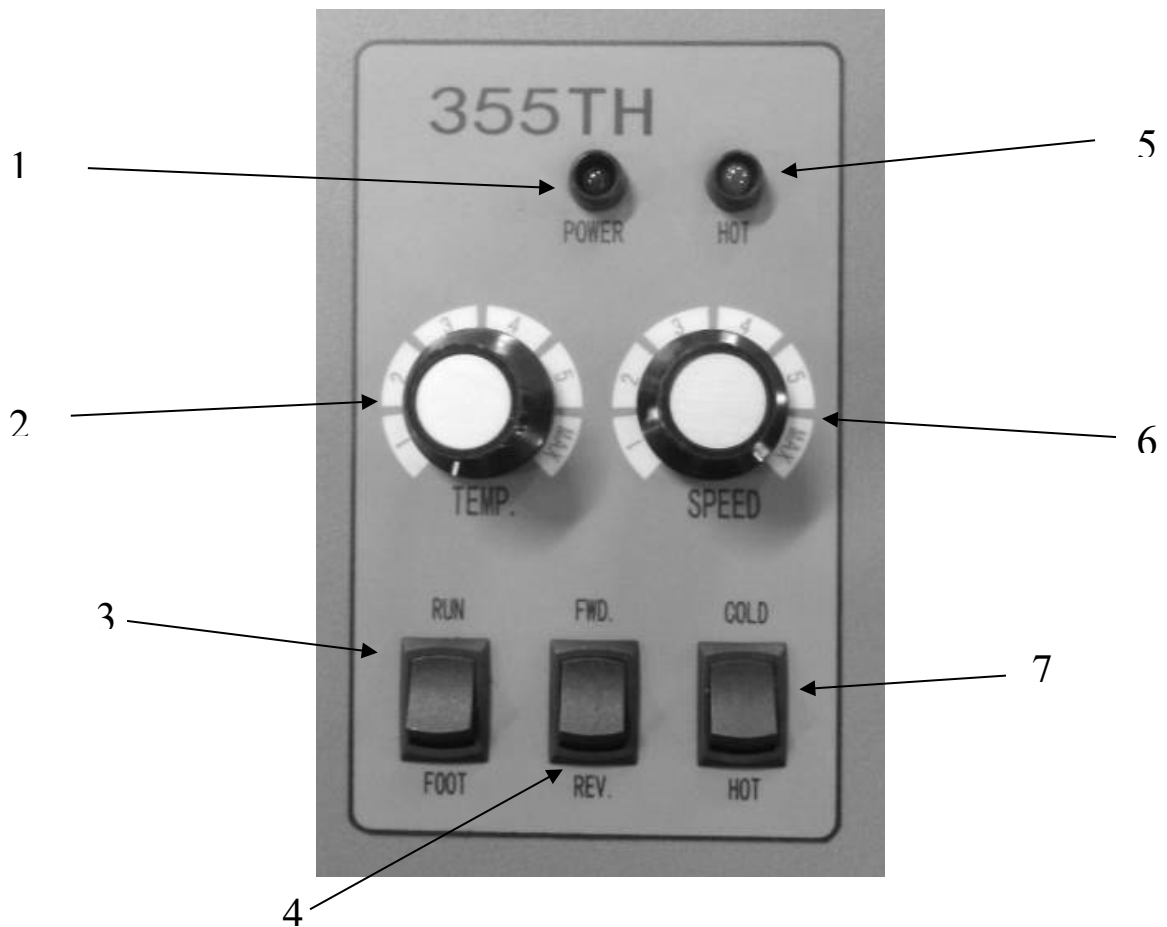

- |                            |  |
|----------------------------|--|
| 1. POWER on indicator      | 5. HOT Lamination indicator              |
| 2. Temperature adjustment  | Flashing = warming up / Solid on = Ready |
| 3. RUN/FOOT pedal switch   | 6. Speed adjustment                      |
| 4. FORWARD/ REVERSE switch | 7. COLD/ HOT on switch                   |

### Note:

1. The machine does not have continuous reverse. Reverse can only operate using the pedal switch
2. If the photo-electric eye stops the machine, move operation switch to "FOOT" then back to "RUN" to continue operation.
3. The photo eyes are located on each side frame and shoot a beam across the front of the rollers on top of the feed table.
4. **Beginning with S/N 1905355TH069 and 1903363TH043, the POWER indicator will start flashing whenever an E-Stop switch is engaged. Release the E-Stop to continue running.**



## 9. Packing List

Remove all parts from shipping crate and boxes. Inspect parts and the machine carefully. Any missing parts should be reported to the shipper upon receipt of shipment.

<b>Main Machine Crate</b>			
<b>Part</b>	<b>Quantity</b>	<b>Part</b>	<b>Quantity</b>
Main Machine	1	Allen Wrench 3mm	1
Quick-Grip shafts	4	Allen wrench 4mm	1
Stand locking screw	4	Allen wrench 6mm	1
Cardboard rewind tube	1	T-Allen wrench 5mm	1
Foot switch	1	Hex screw 8mm x 80	8
Zippy knife	1	Hex screw 8mm x 20	4
Cloth tray	1	Flat washer 8	12
Velcro Straps	7	Lock washer 8	12
Right stand side frame	1	Operating manual	1
Left stand side frame	1		
Upper cross member	1		
Lower cross members	2		
Media alignment disks	2		

## 10. Installation

### 10A. Uncrate the machine

1. Remove screws holding the top cover to the crate side panels (figure 1)
2. Lift off the crate top and remove the supporting cross members from the crate side panels (figure 2)

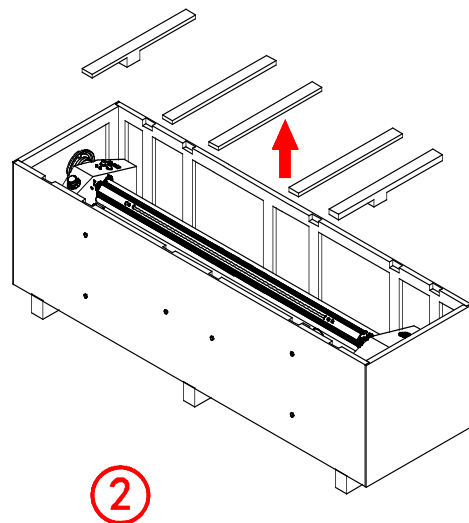
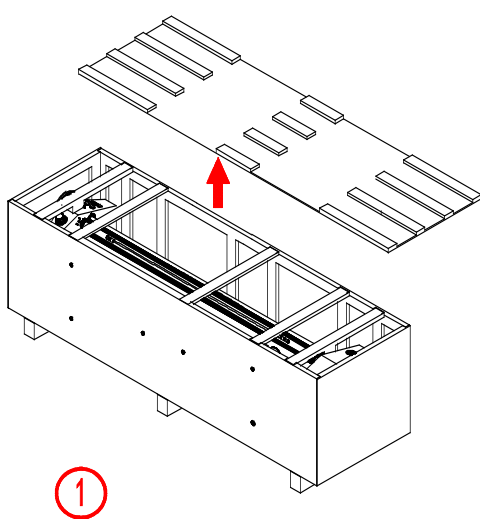

3. Remove screws holding all 4 side panels to the skid (figure 3)
4. Remove the stand side frames from the crate side panel (figure 4)

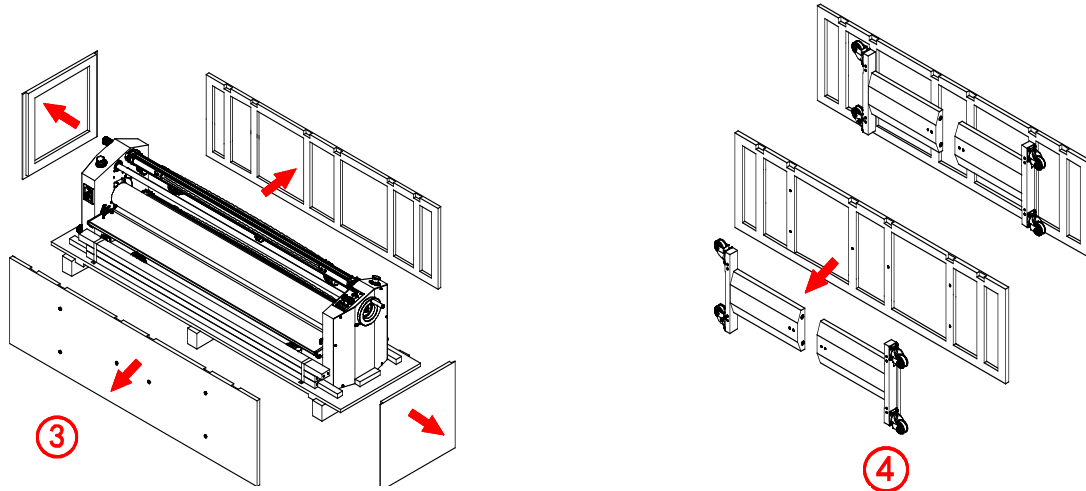

Stand side frames

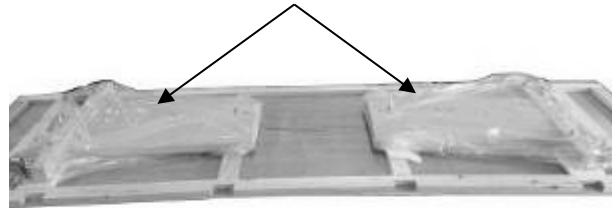

### 10B. Remove stand cross members from machine skid

1. Remove (4) stand cross members bolted under the machine
2. Pull plastic cover down away from machine



## 10C. Assemble machine stand

1. Locking casters are used toward the front of the machine
2. Start all screws by hand before tightening
3. Each screw takes a flat washer and lock washer – Flat washer against the stand.
4. Bolt two (2) lower cross members to stand side frames using (8)- 8mm x 80 Hex screws
5. Bolt upper member to stand side frames using (8)- 8mm x 20 Hex screws
6. Lay cloth tray across two lower cross members
7. Attach tray to cross members using (7)- Velcro straps

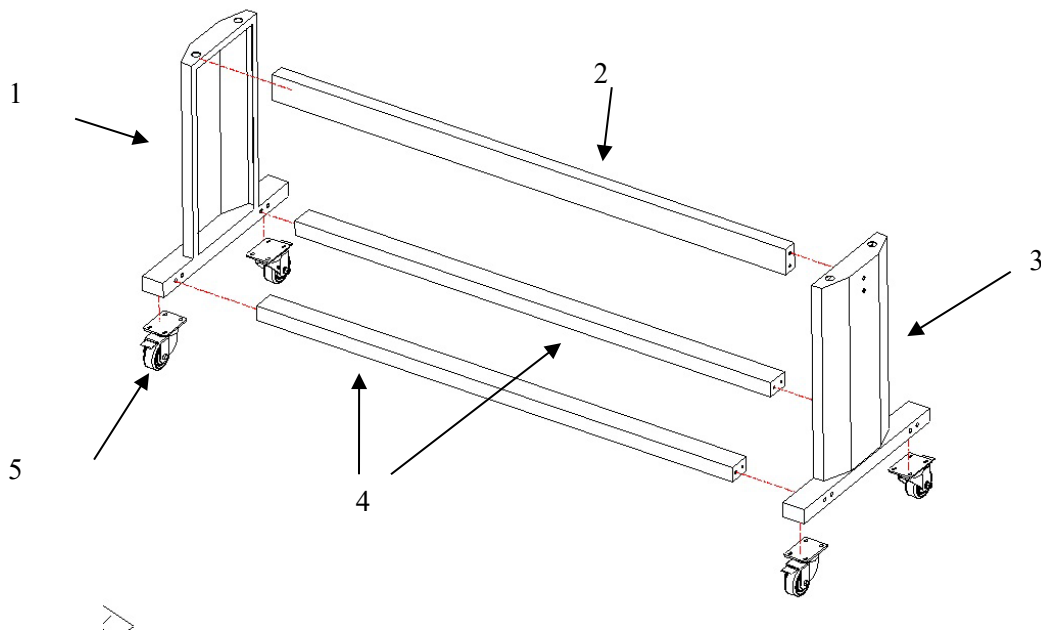

1. Left stand side frame
2. Upper cross member
3. Right stand side frame
4. Lower cross members
5. Locking caster

## 10D. Set machine on stand

1. Remove machine from the crate base
2. Lift machine onto support stand  
(Note locking casters are toward the front of the machine)

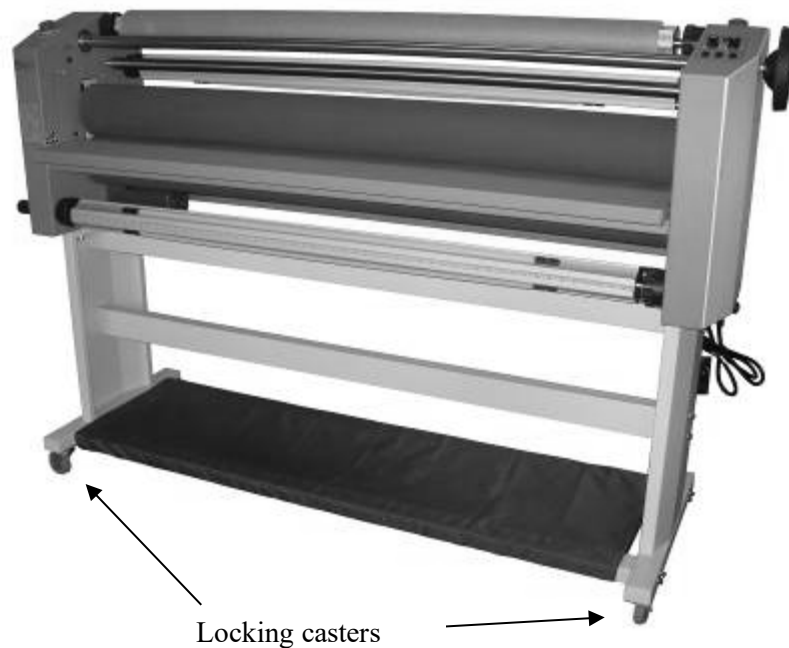

***Heavy! Handle with care!!***

***Warning: when moving the machine, lift by using the hand lift openings on the front and rear panels. Do not use roller gap adjustment hand-wheel for lifting! The machine is heavy; use caution and good lifting practices when moving the machine to the stand.***

### 10E. Bolt Machine to Stand

1. Secure machine to stand from underside of each side frame using (2) chrome stand locking screws on each side of stand



## 11. Additional Installation items

1. Plug foot pedal into rear panel near power cord
2. Check drive chains for tightness
3. Check all drive set screws for tightness
4. Check all electrical connections and input power and test for proper operation

## 12. Loading upper shafts

### 12A. Remove upper supply and rewind shafts

1. Remove and load the upper shafts from the rear of the machine
2. Rotate the locking outer sleeves on both sides in the direction of the arrow to their open position, aligned with the inner sleeve indicated in Figure 1
3. Remove both upper shafts

**Figure 1**

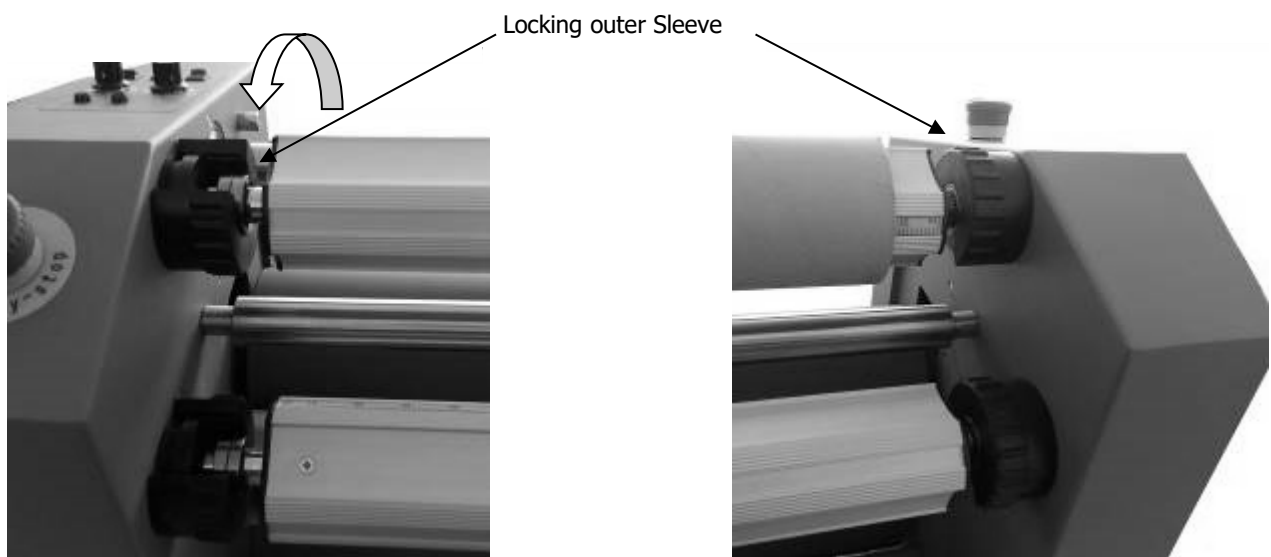

## 12B. Loading film and rewind shafts

3. Cardboard core is used on upper rewind shaft to rewind film liner
4. Slide the new top supply roll onto the supply shaft
  - i. If using Liner-in film, the web should come off the bottom of the roll, for Liner-out film the web should come off the top of the roll (see threading diagram in section #15)
3. Position the roll in the middle of the supply shaft using alignment numbers on the shaft. (Use the same number as the bottom roll in section #13 to align the top and bottom rolls)
5. Insert the ends of both upper shafts into the right shaft housing with tension adjustment knobs and drop shaft into place on left side closest to control panel (see figure 2). **NOTE:** *The shafts are reversible from side-to-side. Ensure that you have loaded the film correctly on the machine before threading.*
6. Rotate all outer locking sleeves to lock shafts in place
5. Adjust the brake tension by turning the Tension adjustment knob (see Adjusting roller tensions section 14)

**Figure 2**

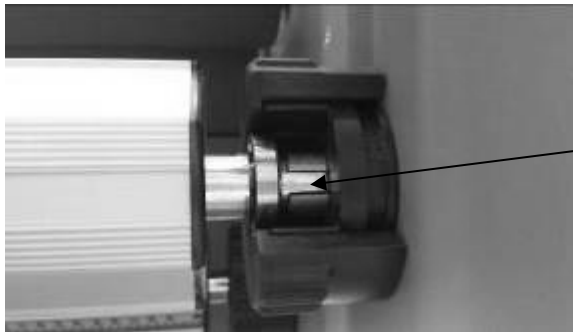

Tongue on the shaft fits in the slot of the cradle



View from rear of machine



## 13. Loading Bottom Supply shaft

1. Remove bottom supply shaft and slide the new roll on
  - a. Position the supply roll using the same number position used on the top supply roll in section #11B to align the top and bottom rolls.
    - i. *When using printed media, position one Media Alignment Disk on each side of the roll to keep edges lined up*
    - ii. *Media rolls can be very slippery and 'telescope' when loading on the supply shaft and running (see picture below).*
2. Adjust the brake tension by turning the adjusting sleeve (see Adjusting Roller tensions section 14)

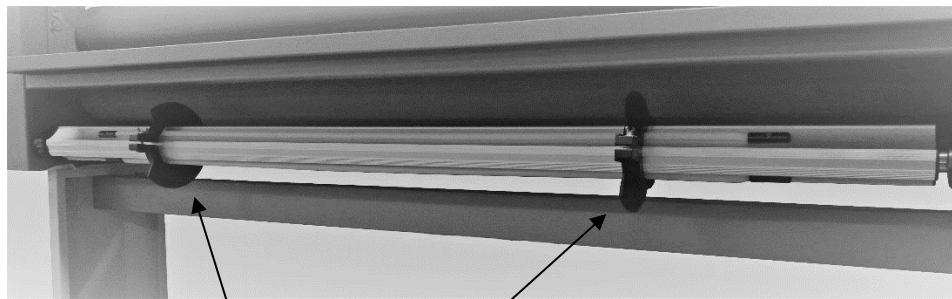
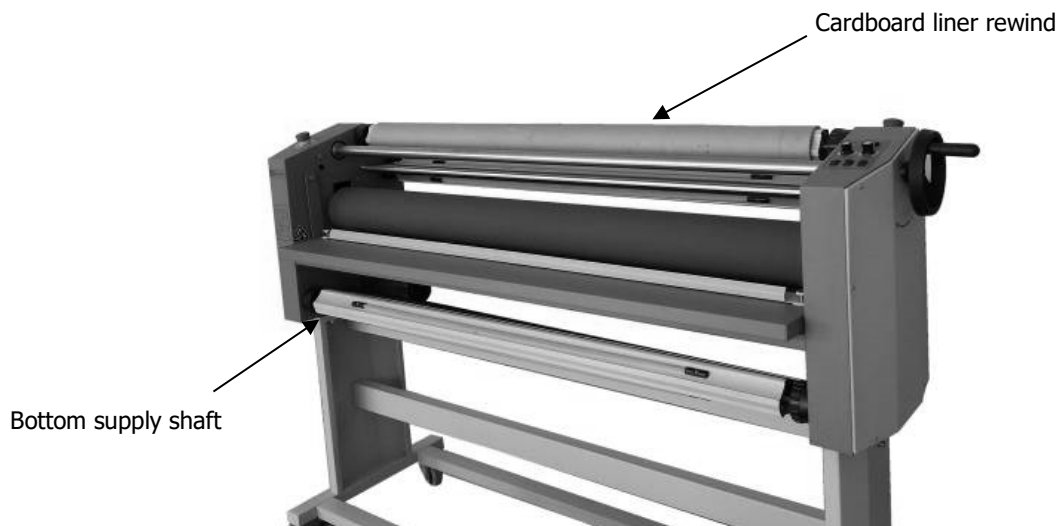

Bottom supply shaft with Media Alignment Disks

**NOTE:** Printed media can be very slippery and 'telescope' when loading on the supply shaft. Use the alignment disks to keep the edges properly lined up.

## 14. Threading Film

1. Turn the pressure-adjusting hand-wheel to lift the upper rubber roller.
2. Pass the top film web under the idler bar and down in front of the roller
3. Separate 1” of paper liner from the film web, attach film web to a leader board the width of the film roll and insert leader board into the rollers
4. Lower the top rubber roller onto the leader board
5. Pull the liner up between the pressure adjustment linkage shaft and the Top Idler bar and attach to a cardboard tube on the liner rewind shaft as in the diagrams below
6. Use foot pedal to advance film web until leader board is under the roller
7. Pass the bottom vinyl media or Kraft paper web up behind the bottom idler bar and adhere to the exposed film web as in diagram below. (Position a Mounting adhesive web in front of the idler bar as in diagram below)
8. Use foot pedal to advance both webs until cleared of the nip rollers
9. Lower roller using pressure-adjusting hand-wheel

**Note: The film should be wrinkleless and tight to the surface of the roller. If the film is not tight enough, increase the roller pressure. If wrinkles appear in the film web, adjust the brake tension for the top film supply roll. If wrinkles appear in the bottom media or Paper roll, adjust the brake tension for the bottom roll.**

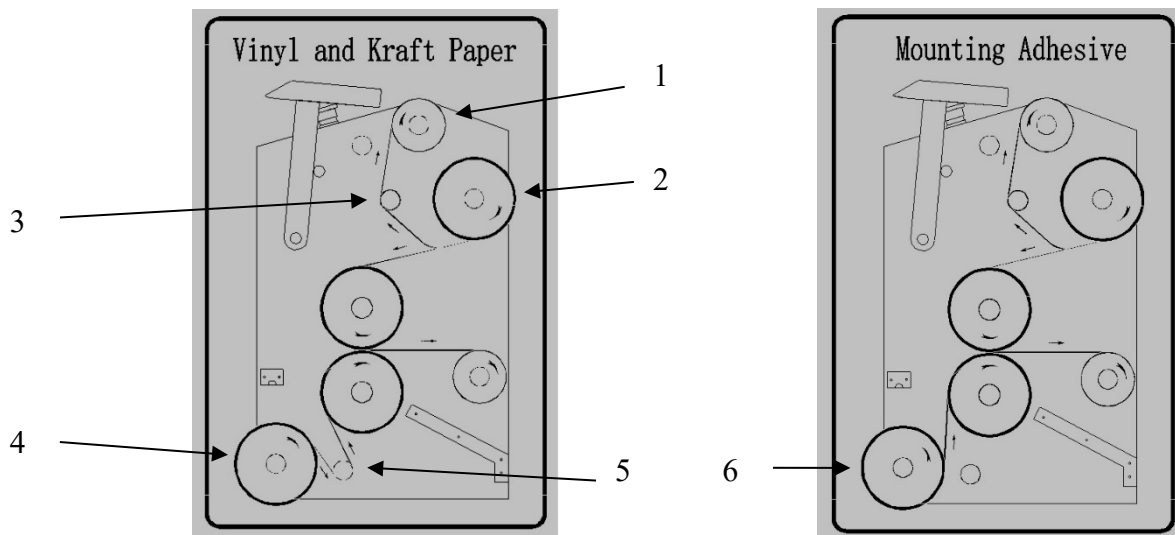

1. Liner Rewind  
2. Top supply roll

3. Top idler bar  
4. Media or Kraft paper

5. Bottom idler bar  
6. Mounting adhesive

## 15. Adjusting Brake/Clutch Tensions

1. Supply roll brake tension adjustment
  - a. Top supply roll brake adjustment knob is #1 below
  - b. Bottom supply roll brake adjustment knob is #2 below
  - c. Rotate adjustment knob clockwise to increase tension and counterclockwise to loosen
  - d. Apply only enough brake tension to remove wrinkles from the vinyl web before it enters the nip rollers

Note: Brake tension should not prevent roll from turning

Note: Excessive brake tension will cause waves or wrinkles in vinyl
2. Rewind roll clutch adjustment
  - a. Top liner rewind clutch adjustment knob is #3 below
  - b. Rear rewind clutch adjustment knob is #4 below
  - c. Rotate adjustment knob clockwise to increase clutch tension and counterclockwise to loosen
  - d. Apply only enough clutch tension for the roller to maintain the same speed as the laminator

Note: Rewind rollers should turn at the approximate speed of the laminator

Note: Excess clutch tension will cause the roller drive to spin faster than the rewind roller shaft

Note: Insufficient clutch tension will cause the rewind rollers to not keep pace with the laminator

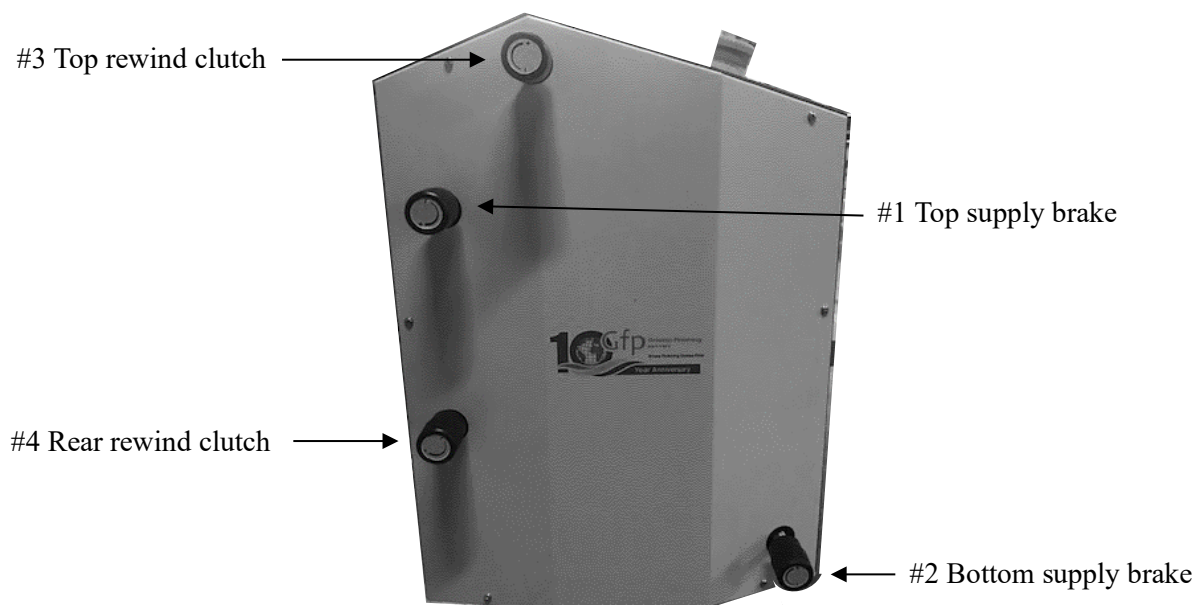

## 16. Operation

1. Plug power cord into a proper receptacle

-  Connect the attachment plug provided with the laminator to a suitably grounded outlet only. This machine must have reliable earth wire to ensure the safety of the machine during operations
  - Contact an electrician should the attachment plug provided with the laminator not match the receptacles at your location
  - Ensure that the voltages of the power supply you are using match the rated working voltages before operations. Do not use incorrect power supply
  - Do not use damaged wires or sockets. If abnormal conditions occur, switch off the power supply first.
2. Turn power to “ON” with the rear power switch
  3. **Cold laminating:** When doing cold laminating, turn the switch to ‘COLD’
  4. **Hot Laminating:** Turn switch to “HOT” position
  5. Dial the “TEMP” control to the desired temperature
    - a. For most vinyl media applications use setting 4 as a starting point
  6. The “HOT” indicator light will flash when the top roller is heating
  7. When the “HOT” indicator light turns solid, the rollers are up to temperature

**NOTE: The temperature should meet the material to be laminated. If too high, the quality will be affected**

## 17. Roller Gap

1. When the pressure-adjusting hand-wheel is turned clockwise, the top rubber roller comes down and the pressure will increase
2. With a counter-clock turn, the top rubber roller goes up and the pressure will decrease.
3. Too much nip pressure will wrinkle the output. Bring the nip roller down only to touch the two webs together.

## 18. Laminating

**Note: It is hard to remove film adhesive once it gets onto the rubber rollers. When laminating, always use materials the same width as the film roll. If your sheets are narrower than the film roll, use a laminating sled or Kraft paper roll on the bottom to keep the film adhesive from sticking to the bottom rubber roller of the machine. Always use a media roll the same width or wider than the film supply roll.**

**To clean the rollers, use rubber eraser or Isopropyl Alcohol and a shop towel.**

### 18 A. Single Sheets using a sled

- Load a roll of laminating film on the top roller  
(see loading upper shafts section 11)
- Turn the pressure-adjusting hand-wheel to lift the upper roller.
- Select a piece of Gatorboard or other PVC mounting board the width of the film web to use as a sled under the print to be laminated
- Insert the sled between the nip rollers and lower the top roller until it touches the sled
- Reverse the motor to back the sled out of the rollers
- Pass the film web under the idler bar and down in front of the roller
- Separate 1” of the paper liner from the film web, attach film web to a leader board the width of the film roll and insert leader board into the rollers
- Use foot pedal to advance the film web half way through the roller and stop
- Position print on the sled
- Depress the foot switch and run sled through
- Insert another leader board or next sled right behind the first sled

### 18 B. Multiple sheets using a roll of Kraft paper

- Load a roll of laminating film on the top unwind Supply Shaft  
(see Loading upper shafts section 11)
- Load a roll of Kraft Paper on the bottom, front unwind Supply shaft, unwinding from the BOTTOM of the roll
- Thread both rolls through machine (see Threading film section 13)
- Press RUN
- Feed single sheets continuously

### 18 C. Media from a roll

- Load a roll of laminating film on the top unwind Supply Shaft (see Loading upper shafts section 11)
- Load a roll of printed media on the bottom, front unwind Supply shaft, unwinding from the TOP of the roll
- Thread both rolls through machine (see Threading film section 13)
- Press RUN



## 19. Mounting

### 19A. Pre-coating mounting boards

- Load a roll of mounting adhesive on the top roller  
(see Loading upper shafts section 11)
- Insert leader board the same thickness as the board to be coated and the width of the mounting adhesive, between the nip rollers and lower the top roller until it touches the board
- Pull mounting adhesive down over the idler bar and over the front of nip roller and adhere to the leader board
- Run leader board half way through the roller and stop
- Insert mounting board to be coated and depress foot switch
- After the last board, insert leader board to keep adhesive from contacting the rollers

### 19B. Mounting print to a pre-coated mounting board

- Pull back and fold down 1” of the liner from the pre-coated mounting board
- Adhere leading edge of the print to the exposed adhesive on the board
- Insert leading 1” of the board into the nip rollers
- Lower the roller
- Lay print over top nip roller
- Hold release liner on board with one hand and apply pressure to print as it comes over the top roller.
- Depress the foot switch to run the board and print through the rollers



## 20. Troubleshooting

Problems	Causes	Solutions
Machine does not turn on	<ol style="list-style-type: none"> <li>1. No power supply</li> <li>2. Main power switch is OFF</li> <li>3. Circuit breaker has tripped</li> <li>4. Blown main power fuse</li> <li>5. Motor has failed</li> </ol>	<ol style="list-style-type: none"> <li>1. Plug in power cord</li> <li>2. Place power switch to ON</li> <li>3. Reset circuit breaker</li> <li>4. Replace fuse on rear panel</li> <li>5. Change the electric motor</li> </ol>
Rollers do not turn after "RUN" button is pressed	<ol style="list-style-type: none"> <li>1. Emergency switch is engaged</li> <li>2. Excess roller nip pressure</li> </ol>	<ol style="list-style-type: none"> <li>1. Disengage emergency switch</li> <li>2. Reduce the nip pressure of the rubber rollers</li> </ol>
POWER LED is flashing	<ol style="list-style-type: none"> <li>1. Emergency switch is engaged</li> </ol>	<ol style="list-style-type: none"> <li>1. Disengage emergency switch</li> </ol>
Poor film adhesion or cloudy prints	<ol style="list-style-type: none"> <li>1. Nip roller pressure to low.</li> <li>2. Dust on the surface of the print</li> </ol>	<ol style="list-style-type: none"> <li>1. Increase nip roller pressure</li> <li>2. Clean print surface before lamination</li> </ol>
Poor film adhesion on one side	<ol style="list-style-type: none"> <li>1. Nip roller pressure on the two sides is not even</li> </ol>	<ol style="list-style-type: none"> <li>1. See "Roller gap adjustment"</li> </ol>
Lamination output is curled	<ol style="list-style-type: none"> <li>1. Sheet is curled upward</li> <li>2. Sheet is curled downward</li> </ol>	<ol style="list-style-type: none"> <li>1. Reduce top roll tension</li> <li>2. Reduce bottom roll tension</li> </ol>
Film supply roll gets loose during operation	<ol style="list-style-type: none"> <li>1. Not enough brake tension on supply roll</li> </ol>	<ol style="list-style-type: none"> <li>1. Increase brake tension on supply roll</li> </ol>
Backing paper gets loose when being rolled up	<ol style="list-style-type: none"> <li>1. Not enough brake tension on the backing paper rewind roller</li> </ol>	<ol style="list-style-type: none"> <li>1. Increase brake tension on backing paper rewind roller</li> </ol>
Wrinkles in film both on top and bottom	<ol style="list-style-type: none"> <li>1. Too much nip roller pressure</li> </ol>	<ol style="list-style-type: none"> <li>1. Reduce nip pressure with hand wheel</li> </ol>



## 21. Specifications

Description	355TH	363TH
Laminating Width	55"	63"
Roller Diameter	5"	5"
Roller Gap	1"	1"
Rear rewind	Chain drive	Chain drive
Max Temperature	140° F	140° F
Laminating Speed	0- 20 Ft/min	0- 20 Ft/min
Unwinds	Top and bottom	Top and bottom
Film core size	3"	3"
Liner rewind	Chain drive	Chain drive
Pressure adjustment	Single Hand Wheel	Single Hand Wheel
Tension adjustment	Single Knob	Single Knob
Heat method	Metal Allow Heater	Metal Allow Heater
Max roller diameter	6" OD	6" OD
Output height	38"	38"
Power Supply	AC120v 60Hz	AC120v 60Hz
Power Consumption	1300W/11A	1440W/12A
Foot pedal	Included	Included
Stand with casters	Included	Included
Net weight w/stand	321 lbs.	376 lbs.
Dimensions	72" x 23.5" x 48.5"	80" x 23" x 48"
Shipping weight Machine/ stand	436 lbs.	507 lbs.
Shipping dimensions machine	79" x 26" x 31"	87" x 26" x 31"
Fuse	(1) 1 amp, 5 x 20 mm	(1) 1 amp, 5 x 20 mm



## 22. Warranty

June 2023

Graphic Finishing Partners, LLC warrants each new Gfp Laminator is free from defects in material and workmanship for a period of one (1) year from the date of installation. A machine which proves defective in materials or workmanship within the warranty period will be repaired or, at Gfp's option, replaced without charge. This warranty is extended only to the original purchaser.

This warranty is the only warranty made by Gfp and cannot be modified or amended. Gfp's sole and exclusive liability and the customer's sole and exclusive remedy under this warranty shall be, at Gfp's option, to repair or replace any such defective part or product. These remedies are only available if Gfp's examination of the product discloses to Gfp's satisfaction that such defects actually exist and were not caused by misuse, neglect, attempt to repair, unauthorized alteration or modification, incorrect line voltage, fire, accident, flood or other hazard.

The warranty made herein is in lieu of all other warranties, expressed or implied, including any warranty or merchantability or fitness for a particular purpose. Gfp will not be liable for personal damage or personal injury (unless primarily caused by its negligence), loss of profit, or other incidental or consequential damages arising out of the use or inability to use this equipment.

This warranty specifically does not cover damage to laminating rollers caused by knives, razor blades, or any sharp objects or abrasives, or failure caused by adhesives, or damage caused by lifting, tilting and/or any attempt to position the machine other than rolling on the installed castors or feet on even surfaces, or improper use of the machine. Warranty repair or replacement by Gfp or its authorized reseller(s) does not extend the warranty beyond the initial period from the date of installation. Unauthorized customer alterations will void this warranty.

### **Contact Information**

#### CORRESPONDENCE:

Graphic Finishing Partners LLC  
PO Box 1097  
Maryland Heights, MO. 63043  
800-986-2005  
[sales@gfpartnersllc.com](mailto:sales@gfpartnersllc.com)  
[www.gfpartnersllc.com](http://www.gfpartnersllc.com)

#### SHIPPING:

Graphic Finishing Partners LLC  
13878 Parks Steed Drive  
Earth City, MO. 63045

#### PARTS:

[parts@gfpartnersllc.com](mailto:parts@gfpartnersllc.com)

#### SERVICE:

[service@gfpartnersllc.com](mailto:service@gfpartnersllc.com)